

Abril del 2012

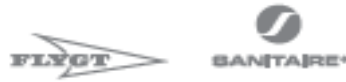

xylem
Let's Solve Water

Productos Sanitaire

Sistemas de Aireación, ICEAS

POR: JONATHAN RAMIREZ



Aplicaciones de aireación dentro del tratamiento



Eficiencia de Aeración Burbuja Fina Comparativo con Otras Tecnologías

Condiciones Estándares

- Burbuja Fina (Cobertura de Piso Lleno) 4.0 - 6.6 kgO₂/kV-h
- Burbuja Fina (Rollo Espiral) 2.0 - 4.0 kgO₂/kV-h
- Aeración Jet 2.2 - 3.5 kgO₂/kV-h
- Aeración Mecánica 1.1 - 2.1 kgO₂/kV-h
- Burbuja Gruesa 1.3 - 1.9 kgO₂/kV-h
- Aeración Aspirada 0.5 - 0.8 kgO₂/kV-h



Información de ASCE WEF Manual of Practice 8: Design of Municipal Wastewater Treatment Plants.

Portafolio de productos de Aireación Sanitaire/Flygt

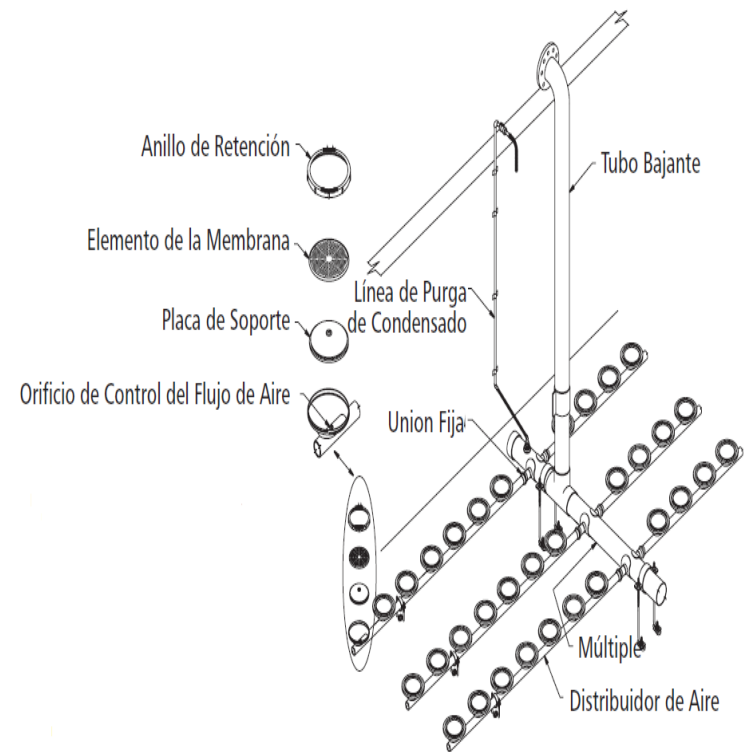

Aireación Burbuja Fina– Disco de Ceramica

- Lanzado al mercado en 1978
- Más de 6,000,000
Mundialmente Instalados
- Sistema de Tubería y Soporte
Comprobado
- Opciones Disponibles de
Monitoreo de Presión y
Limpieza



Aireación Burbuja Fina– Difusores de Membrana

- Lanzado al mercado en 1986
- Más de 14,000,000 difusores Mundialmente en Operación
- El Mismo Sistema de Tubería y Soporte Comprobado como el Disco de Ceramica
- Resistente a “Fouling” a taparse
- Aplicaciones de Aire Abierto/Cerrado
- Como RBS y Digestores

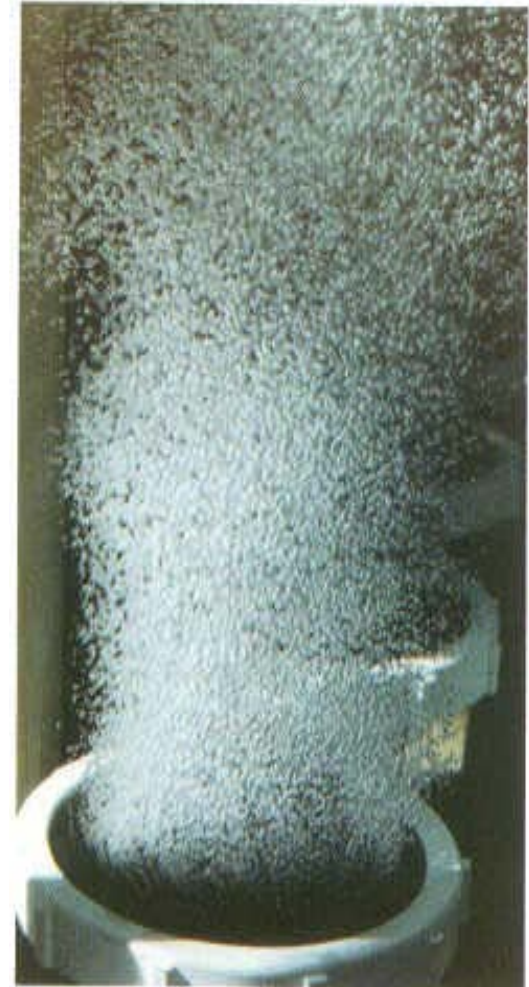

Difusores de Burbuja Gruesa de Banda Ancha

- Bajo Mantenimiento
- Buenos mezcladores
- Aplicaciones industrial
- Conveniente para aplicaciones “aire abierto/cerrado”
- Caudal de transferencia de oxígeno baja
- Usado donde el uso de la energía es de poca importancia



Sanitaire Difusor: Gold Series



- SOTE 20% más alto, en comparación con burbuja fina.
- Perdida de carga similar a los discos

- SAE - Eficiencia de Aeración Estandar más alta

- Unidades modular para reducir tiempo de instalación

- Se puede reemplazar la membrana en el campo



Jet Aerator: Transferencia de oxígeno y Mezclado

- 1 - 70 kW.
- SOTR 1 - 80 kg O₂/h .
- SAE alrededor 0,5 hasta 1.2 kg O₂/kWh.
- Posible instalarlo e izarlo sin necesidad de vaciar el tanque.
- Tecnología de impulsor N inatascable.
- Aspiración Máxima de 7 m.

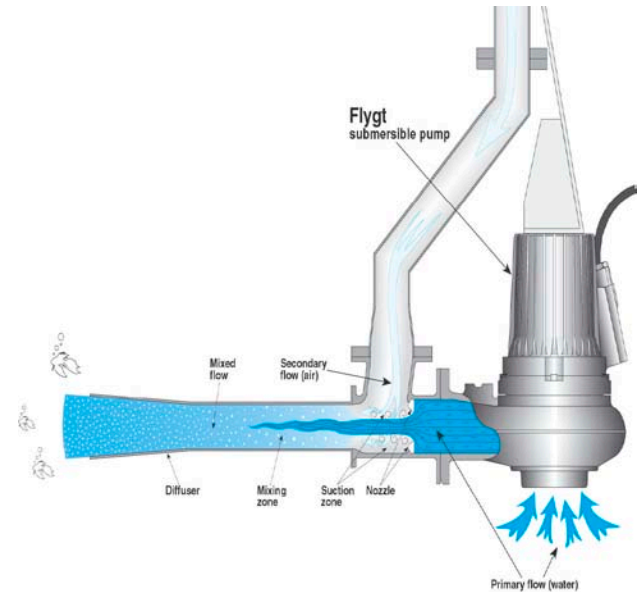

No sopladores
No cabezales de aire
No tubería en el tanque

Panel para el monitoreo de presión

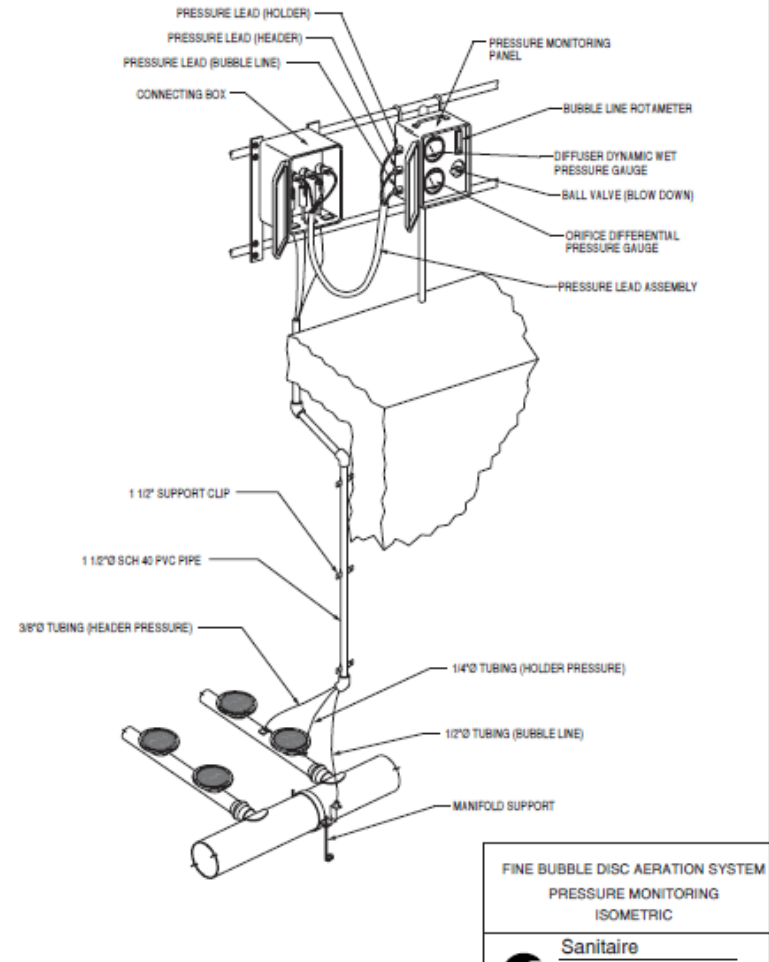

Sistema de limpieza química

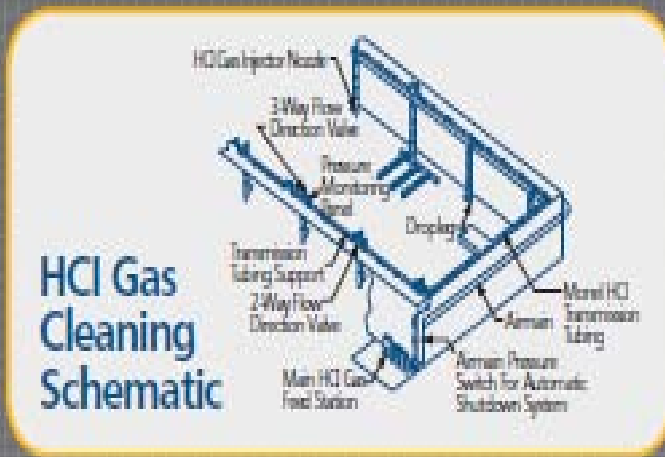

Pruebas de transferencia de oxígeno



Mezcladores Sumergibles

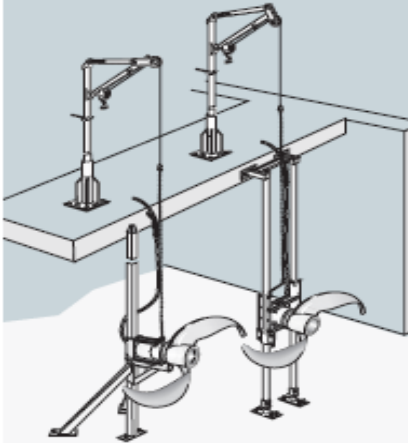

Sistema con una barra-guía
Un método de uso frecuente, que elimina el riesgo de fatiga y proporciona una instalación rentable.

Sistema con dos barras-guía
Sistema rígido que también permite instalar varios agitadores a distintas profundidades.

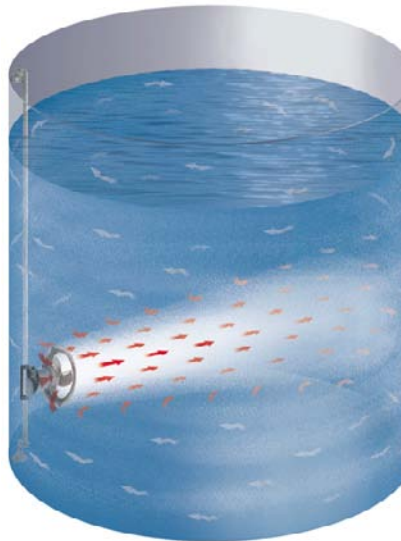

ICEAS

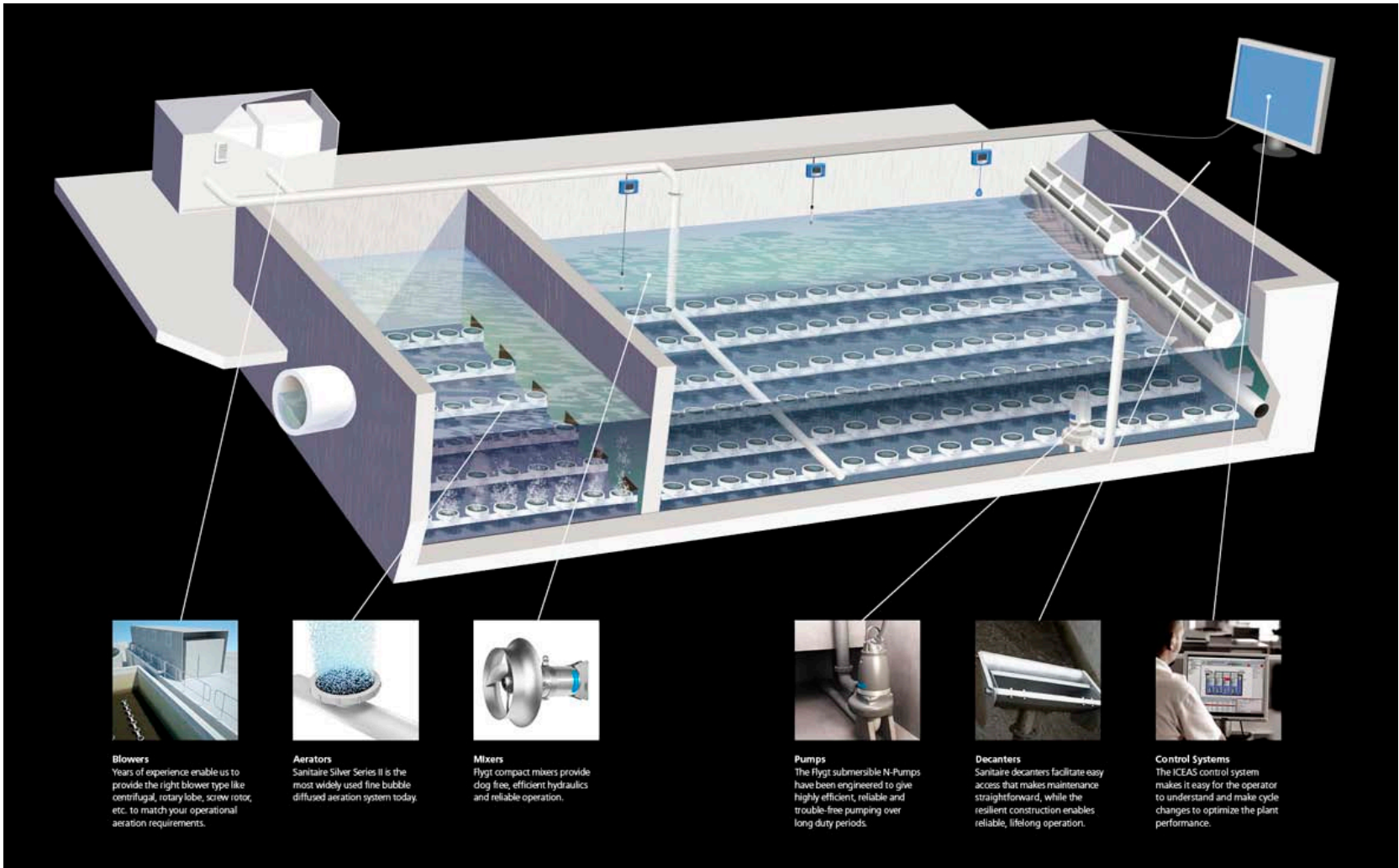

Blowers

Years of experience enable us to provide the right blower type like centrifugal, rotary lobe, screw rotor, etc. to match your operational aeration requirements.



Aerators

Sanitaire Silver Series II is the most widely used fine bubble diffused aeration system today.



Mixers

Flygt compact mixers provide dog free, efficient hydraulics and reliable operation.



Pumps

The Flygt submersible N-Pumps have been engineered to give highly efficient, reliable and trouble-free pumping over long duty periods.



Decanters

Sanitaire decanters facilitate easy access that makes maintenance straightforward, while the resilient construction enables reliable, lifelong operation.

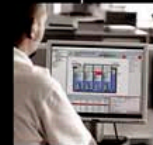

Control Systems

The ICEAS control system makes it easy for the operator to understand and make cycle changes to optimize the plant performance.

Equipo del Proceso de – Visión General ICEAS

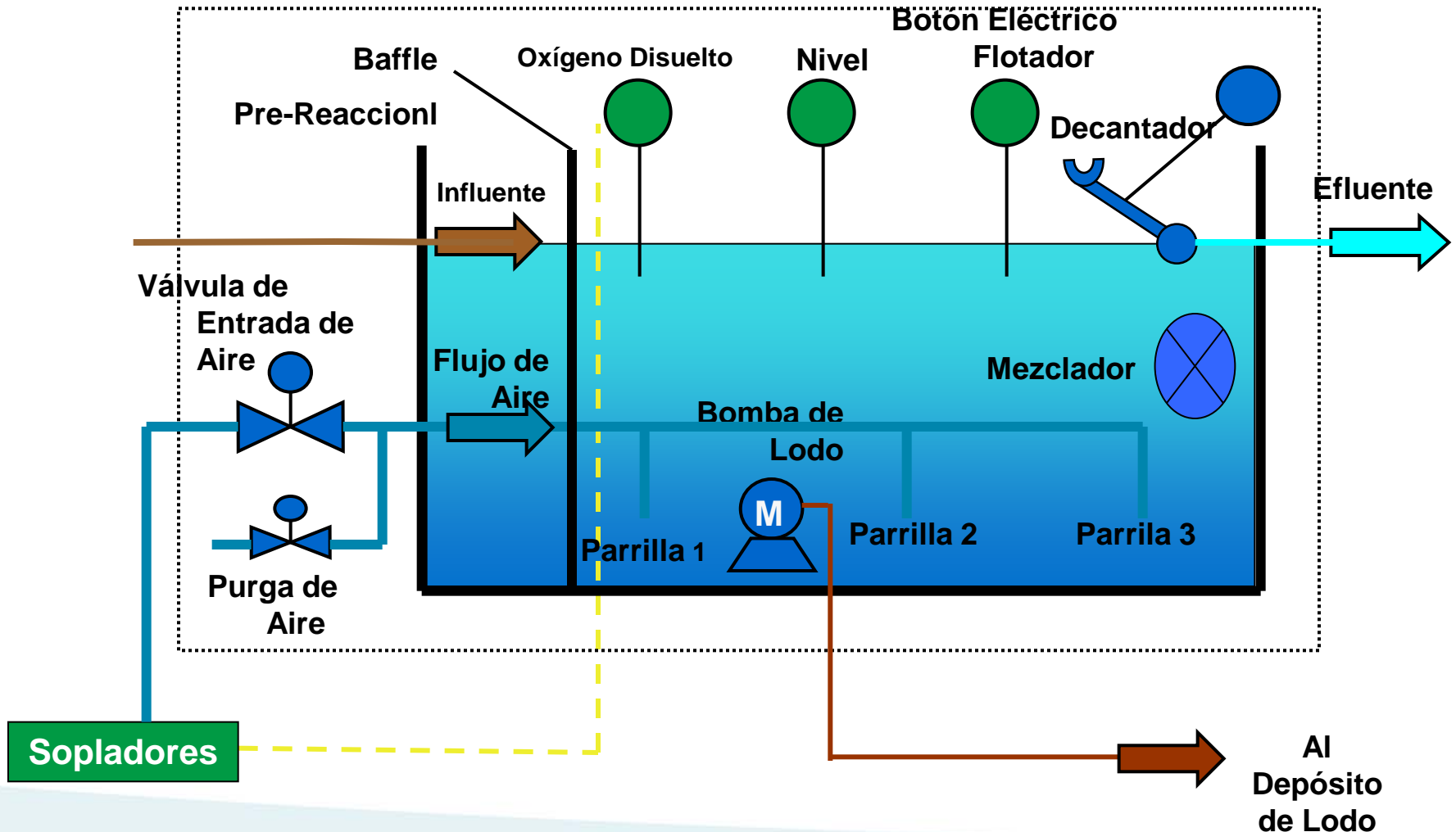

Ingeniería Xylem Water Solutions

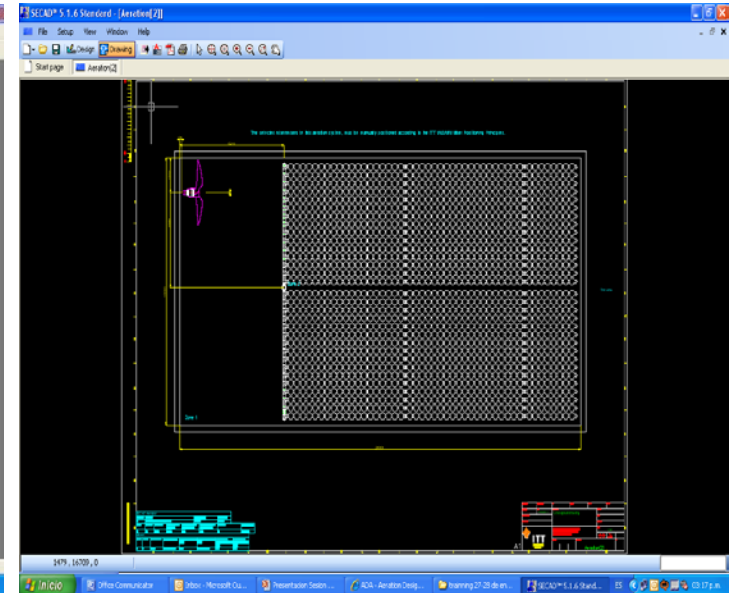
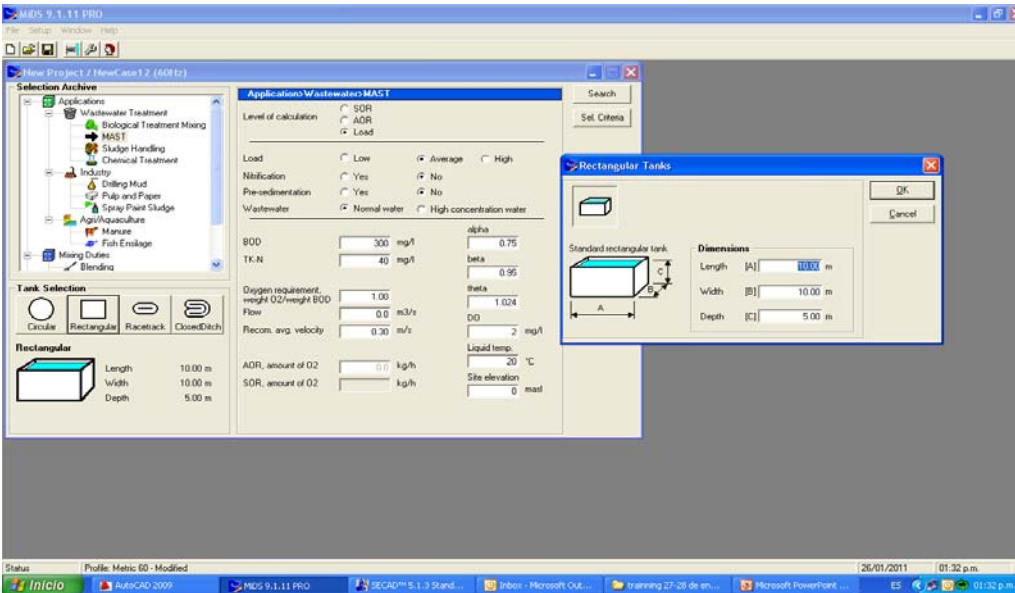
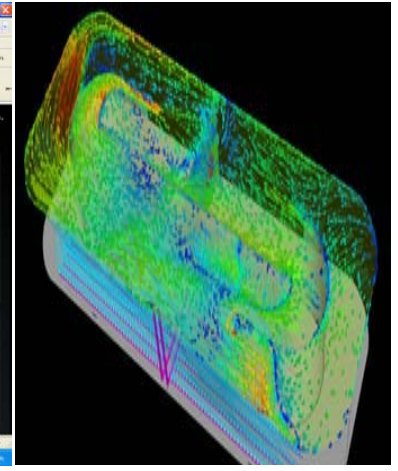
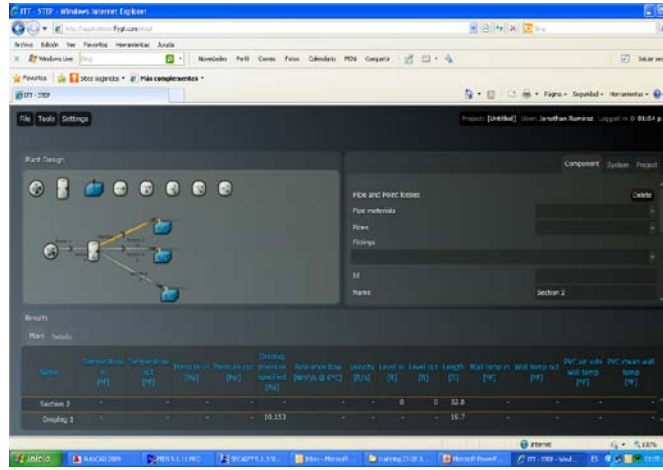
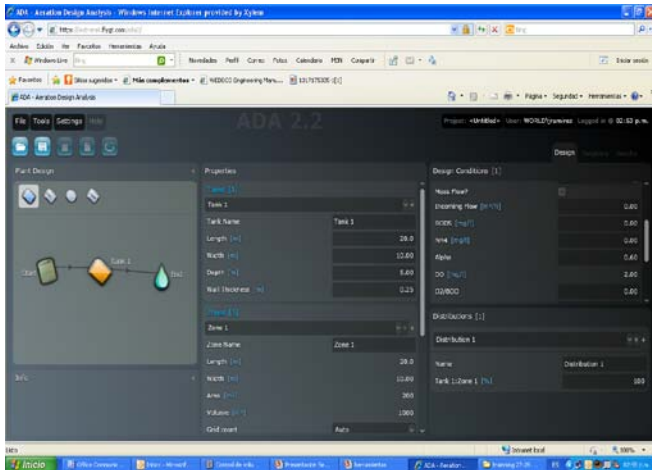



SANITAIRE
a xylem brand

Preguntas ?

Gracias por su atención!!!

